

SureShell Carrier Fallon Rail Manual

46010 rev e

Contents

- SureShell shotshell carriers Overview 2
 - Yoke 2
 - Backplate or Bracket 2
 - Retention Tubing 2
 - Mounting Hardware 3
 - About the M-LOK® slots 3
- Package Contents 3
- Installation 3
 - Tools Required for Installation 4
 - Remington 870 Tac-14 4
 - Mossberg 590 Shockwave 7
 - Remington Tac-13 11
- Appendix A: Remington 870 Tac-14 Hole Pattern 12
- Support and Warranty 13

SureShell shotshell carriers Overview

All Mesa Tactical SureShell shotshell carrier assemblies are comprised of three basic components:

- The yoke
- The backplate or bracket
- The retention tubing

Yoke

The yoke is the component that holds the shotshells. The yoke can hold four, six, or eight shells, and is made out of machined aluminum or injection-molded glass-filled nylon. Either 12 gauge or 20 gauge shells are supported, depending on application. The yoke is secured to the backplate or bracket with between two and ten #6 Phillips head screws.



[illustration 460130_01.jpg]

Backplate or Bracket

The backplate or bracket is the platform specific part of the assembly. It is designed to fit onto particular shotgun models and may include a Picatinny rail profile, integrated reflex sight mount or a simple plate for mounting onto the side of a shotgun receiver.

Retention Tubing

One (with aluminum yokes) or two (with polymer yokes) synthetic rubber tubes run the length of the assembly, sandwiched between the yoke and the backplate. This tubing is what secures the shotshells in place in the yoke.

For most users, the factory-installed tubing will perform a lifetime of service; but frequent use of the SureShell shotshell carrier may result in wear of the tubing. For this reason, the tubing can be

thought of as a consumable that in some cases may have to be replaced from time to time. Replacement tubing is available from Mesa Tactical, free of charge.

The SureShell shotshell carrier package includes a stiffer tubing (white) that in some cases provides more secure shell retention than the factory installed (black) tubing. If necessary, the black tubing can be replaced with the white tubing by disassembling the SureShell shotshell carrier assembly by removing the screws securing the yoke to the backplate. Of course, worn tubing can be replaced in the same way at any time.

Mounting Hardware

The mounting hardware is packaged in a zip lock poly bag and is specific to the SureShell shotshell carrier application. Simple installation tools, such as hex keys, are often included with the mounting hardware.

About the M-LOK® slots

The SureShell shotshell carrier with Fallon rail features M-LOK accessory mounting slots. The versions for the Remington 870 Tac-14 and Mossberg 590 Shockwave have two slots, one on each side of the barrel; while the version for the Remington Tac-13 has a single slot on the left side of the barrel.

Some M-LOK screw hardware may be too long for use with the SureShell shotshell carrier with Fallon rail and may have to be replaced or ground down.

Package Contents

The SureShell shotshell carrier package includes:

- This Installation Manual;
- A SureShell shotshell carrier assembly (yoke, retention tubing and backplate or bracket);
- Mounting hardware kit in a zip-lock poly bag;
- Synthetic rubber backplate gasket;
- One or two spare white retention tubes;
- Mesa Tactical sticker.

If you are missing any items, please contact Mesa Tactical support as described at the end of this Installation Manual.

Installation

Most Mesa Tactical products require no gunsmithing or special tools to install. They usually can be installed on your shotgun or stock at home with tools you have around the house.

IMPORTANT: The SureShell shotshell carrier with Fallon rail requires a drilled and tapped receiver. All of the supported shotgun platforms are drilled and tapped at the factory. Remington 870 Tac-14 shotguns have been drilled and tapped at the factory since 2020 (see below).

Tools Required for Installation

The SureShell shotshell carrier with Fallon rail includes all the special tools necessary to install the shotshell carrier on the shotgun. However, the following tools could make installation easier:

- Higher quality hex keys than those included in the package;
- Scissors or a razor blade for trimming the gasket material, if necessary;
- A brass rod or wooden dowel for bumping the barrel clamp into alignment;
- A vise.

Using a thread lock such as purple or blue Loctite® is not necessary, but is recommended.

Remington 870 Tac-14

IMPORTANT: The SureShell shotshell carrier with Fallon rail requires a drilled and tapped receiver. Remington 870 Tac-14 shotguns have been drilled and tapped at the factory only since 2020; earlier models will have to be drilled and tapped by a gunsmith before the SureShell shotshell carrier with Fallon rail can be installed. A hole pattern diagram is included in the appendix to this instruction manual.

1. Ensure the weapon is unloaded and pointed in a safe direction.

You know the drill. No live ammunition should be present.

2. Apply the adhesive-backed rubber gasket to the *underside* of the shotshell carrier assembly.

This is the only platform where the Mesa Tactical gasket is installed between the top of the receiver and the underside of the rail assembly. The rail itself is machined to fit best with this gasket installed.



[illustration 460130_02.jpg]

3. Attach the clamp hasp to the underside of the of the shotshell carrier assembly.

The nylon clamp hasp is secured to the shotshell carrier assembly with a ½ inch #8-32 flathead screw that engages a nut captured in a pocket in the underside of the hasp. Attach the clamp hasp to the shotshell assembly with the “nose” of the hasp facing forward, so there is a triangular gap between the hasp and the underside of the shell carrier assembly.



[illustration 460130_03.jpg]

4. Install the barrel clamp onto the shotgun barrel.

The barrel must be removed for this step. Refer to the shotgun *Owner's Manual* to remove the barrel.



[illustration 460130_04.jpg]

Slide the clamp over the muzzle of the barrel with the hasp engagement bosses facing down and back (toward the breech), then revolve the clamp so the mounting boss is facing up once it has cleared the front bead sight. Push it as far forward (toward the muzzle) as it can go.

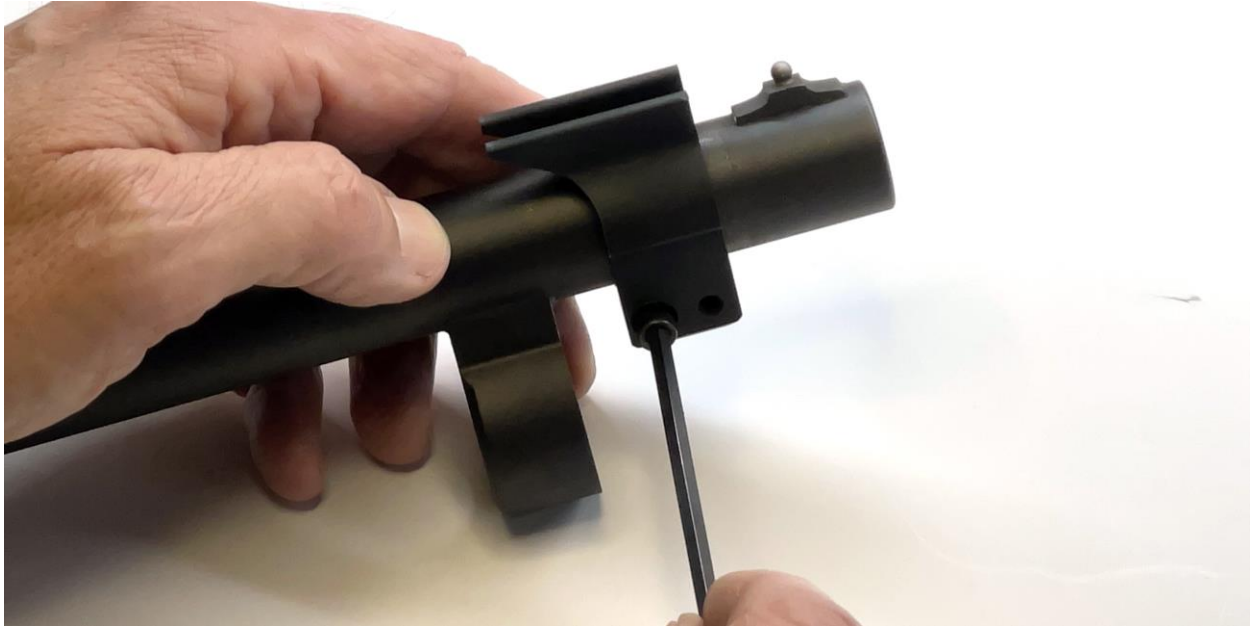

[illustration 460130_05.jpg]

Lightly tighten the two clamp side cap screws enough to keep the clamp in place.

Reinstall the barrel into the receiver.

5. Attach the shotshell carrier assembly to the shotgun receiver.

The shotshell carrier assembly with the adhesive-backed rubber gasket and the clamp hasp installed can be laid over the top of the receiver and secured in place with the three #6-48 mounting screws. Make sure the barrel clamp is pushed as far forward (toward the muzzle) as possible.

You can add a drop of thread locker to each mounting hole before inserting the screw, though note these screws will have to be removed to remove the shotgun barrel.

6. Slide the barrel clamp on the barrel against the clamp hasp.

Now push the barrel clamp back against the hasp on the underside of the shell carrier and rail assembly. When the barrel clamp is as far back as it can go, tighten the clamp to the barrel with the two side cap screws. Once this is done, and the shotshell carrier assembly does not move, the installation is complete.



[illustration 460130_06.jpg]

After taking the shotgun out shooting for the first time, inspect and re-tighten the barrel clamp screws.

To remove the barrel, you will have to uninstall the SureShell shotshell carrier with Fallon rail. The simplest way is to remove the three top mounting screws, and withdraw the assembly from the barrel clamp by moving to backwards.

The barrel can be removed without loosening the barrel clamp by pulling the barrel out of the receiver slightly as the magazine cap is loosened; if the barrel is not moved during this step, the magazine cap will interfere with the barrel clamp. The barrel clamp will remain on the barrel when it is removed.

Mossberg 590 Shockwave

The SureShell shotshell carrier with Fallon rail uses the factory drilled and tapped holes in the top of the shotgun receiver.

1. Ensure the weapon is unloaded and pointed in a safe direction.
You know the drill. No live ammunition should be present.
2. Apply the adhesive-backed rubber gasket to the inside of the shotshell carrier assembly.

The gasket fits against the shallow ledge in the backplate as shown in the illustration below.



[illustration 460130_07.jpg]

3. Slide the barrel clamp onto the barrel and over the barrel ring.

The barrel must be removed for this step. Refer to the shotgun *Owner's Manual* to remove the barrel.

The barrel clamp is asymmetrical; the threaded hole in the top of the mounting boss is slightly forward of center. Slide the clamp over the muzzle of the barrel with the mounting boss facing down and revolve the clamp so the mounting boss is facing up once it has cleared the front bead sight.



[illustration 460130_08.jpg]

Slide the clamp back *halfway* over the barrel ring. The clamp should slide tightly over the barrel ring and stay in place. If it does not fit, remove a little material from the inside surfaces of the clamp with a file or emery cloth.

Reinstall the barrel into the receiver.

4. Attach the rail mounting cleat to the shotgun receiver.

The rail mounting cleat is a steel or nylon part that is secured to the top of the receiver, to which the shotshell carrier assembly is fastened.



[illustration 460130_09.jpg]

If the cleat is steel, simply screw it into the shotgun receiver using four of the approximately 3/8 inch long #8-40 screws. Use of blue thread lock is encouraged on these fasteners as you will rarely remove this cleat for any reason.



[illustration 460130_10.jpg]

If the cleat is nylon, installation is the same as with the steel cleat except four nuts must be inserted into their pockets in the underside of the cleat before it is screwed into the receiver.

Note the steel and nylon cleats have different hole patterns that match the shotshell carrier assembly with which they are shipped. If for some reason you ever need a replacement cleat, be sure to specify which cleat, steel or nylon, you are replacing.

5. Attach the shotshell carrier assembly to the rail mounting cleat.

The four shell carrier mounting screws are just under ¼ inch long. They are #8-40 screws with steel cleats and #8-32 screws with the nylon cleats. Lay the shotshell carrier assembly over the receiver and the mounting cleat and use the four shell carrier mounting screws to secure it to the cleat (or the nuts in the cleat).

You can add a drop of blue thread locker to each mounting hole before inserting the screw, though note these screws will have to be removed to remove the shotgun barrel.

6. Secure the shotshell carrier assembly to the barrel clamp.

With the shotshell carrier assembly firmly attached to the receiver, look through the front mounting hole to align it with the threaded hole in the barrel clamp. Do this by bumping the barrel clamp rearward as necessary with a dowel or brass rod. Once the holes are aligned, use the #8-40 flathead screw just under ½ inch long to attach the shotshell carrier assembly to the barrel clamp.

You can add a drop of blue thread locker to the mounting hole before inserting the screw, though note the screw will need to be removed to take off the shotgun barrel.

To remove the barrel, you will have to uninstall the SureShell shotshell carrier with Fallon rail. The simplest way is to remove the four top mounting screws and the single barrel clamp screw,

and lift the assembly from the shotgun. The barrel clamp should remain on the barrel when it is removed, though the clamp might slide back and forth slightly. When re-installing the barrel, ensure the barrel clamp is correctly located, or located a little forward so it can be tapped back as necessary to accept the shotshell carrier assembly.

Remington Tac-13

The SureShell shotshell carrier with Fallon rail uses the factory drilled and tapped holes in the top of the shotgun receiver, and requires the factory magazine clamp to hold the front of the assembly.

1. Ensure the weapon is unloaded and pointed in a safe direction.

You know the drill. No live ammunition should be present.

2. Apply the adhesive-backed rubber gasket to the inside of the shotshell carrier assembly.

You might need to trim the gasket so it does not overlap the edge of the backplate. This is easier to do, with scissors, before the gasket has been applied.

3. Loosen the magazine clamp.

Loosen the two cap screws securing the magazine clamp to the barrel and magazine so the clamp can move slightly back and forth.

4. Attach the shotshell carrier assembly to the shotgun receiver.

The shotshell carrier assembly can be laid over the top of the receiver and secured in place with the four #6-48 mounting screws.

You can add a drop of blue thread locker to each mounting hole before inserting the screw, though note these screws will have to be removed to remove the shotgun barrel.

5. Secure the shotshell carrier assembly to the magazine clamp.

Line up the hole in the M-LOK flange with the threaded hole in the left side of the magazine clamp. Attach the shotshell carrier assembly to the magazine clamp by running the #10-32 button head cap screw through the M-LOK flange and the black steel spacer into the threaded hole in the magazine clamp.



[illustration 460130_13.jpg]

6. Tighten the magazine clamp.

Once the SureShell shotshell carrier assembly has been attached to the magazine clamp, secure the magazine clamp in place by tightening the two cap screws in the side of the clamp.

To remove the barrel, you will have to uninstall the SureShell shotshell carrier with Fallon rail. Removal is the reverse of the installation procedure. Once the SureShell shotshell carrier assembly is removed, slide the magazine clamp off the shotgun muzzle.

Appendix A: Remington 870 Tac-14 Hole Pattern

The SureShell shotshell carrier with Fallon rail requires a drilled and tapped receiver. Remington 870 Tac-14 shotguns have been drilled and tapped at the factory only since 2020; earlier models will have to be drilled and tapped by a gunsmith before the SureShell shotshell carrier with Fallon rail can be installed.

Use the hole pattern below to drill three holes in the top of the receiver and tap with #6-48 threads (all dimensions in inches):

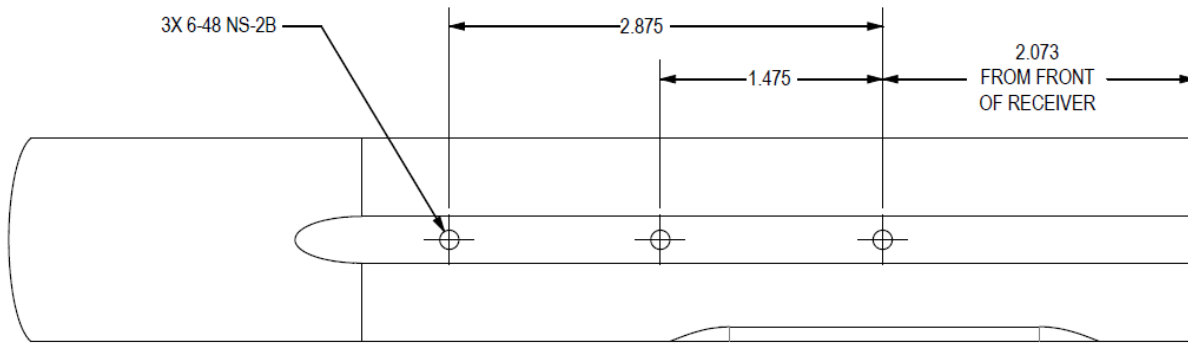

[illustration 460130_14.pdf]

Support and Warranty

If you have any problems or questions, please feel free to contact Mesa Tactical for assistance at 775-333-9800. Sending an e-mail to support@mesatactical.com automatically opens a support ticket.

Mesa Tactical warrants that all products are free from defective material and workmanship and, subject to the conditions set forth below, agrees to repair or replace any part of a product that proves defective by reason of improper workmanship or materials without charge for parts and labor.

In no event will Mesa Tactical be liable for damages, lost revenue, lost wages, lost savings or any other incidental or consequential damages arising from purchase, use or inability to use this product.

No express or implied warranty is made for Mesa Tactical product damaged by accidents, misuse, natural or personal disaster, or any unauthorized disassembly, repair or modification. Mesa Tactical's warranty covers only repair or replacement of defective Mesa Tactical products.

Mesa Tactical
 1775 Kuenzli St
 Reno, NV 89502
 775-333-9800
www.mesatactical.com